

and 3-hydroxy-N-phenoxyethylpyridinium bromide, 2- and 3-acetamino-N-methylpyridinium iodides.

2. Hunt has found that these derivatives of pyridine and piperidine in general have no pronounced effect on the autonomic nervous system. The  $\beta$ -phenoxyethyl-N-methylpyrrolidinium iodide, while giving no muscarine effect, produces an intense stimulating nicotine-like action.

NEW YORK CITY

---

[CONTRIBUTION FROM THE CHEMICAL DEPARTMENTS OF WASHINGTON SQUARE COLLEGE, NEW YORK UNIVERSITY, AND FROM THE CHIEF MEDICAL EXAMINER'S OFFICE, AND BELLEVUE HOSPITAL, NEW YORK CITY]

## THE ISOLATION OF PURE, ANHYDROUS ETHYL ALCOHOL FROM NON-ALCOHOLIC HUMAN AND ANIMAL TISSUES

BY ALEXANDER O. GETTLER, JOSEPH B. NIEDERL AND A. A. BENEDETTI-PICHLER

RECEIVED SEPTEMBER 10, 1931

PUBLISHED APRIL 6, 1932

The object of the present communication is to throw light on the question whether traces of ethyl alcohol are present in human and animal tissues. Some of the earlier workers, notably A. and J. Béchamp, Rajewsky, Vitali, Albertoni, M. Nicloux, Landsberg and Stocklasa,<sup>1</sup> claimed that ethyl alcohol is always present in animal tissues in very small traces, while Arnheim and Rosenbaum, Umber and others claimed that it is absent.<sup>2</sup>

One reason why this problem has not been solved to date is because, if alcohol is normally present at all in organs and tissues, its amount is extremely small. We shall show that distillates from organs contain only about 0.0025% of alcohol at the most and that this small amount is mixed with traces of numerous other volatile organic compounds.

Another reason for disagreement among investigators is the fact that there are no specific tests for alcohol in such dilute solutions. Methods based upon physical constants are all unreliable, both because of the extreme dilution and because of the intermixture of other volatile organic substances. The above experimenters applied the Moore, the Schiff or the Nessler reaction to their oxidized tissue distillates; or tested the distillates directly with Lieben's iodoform or with Nicloux's sulfuric acid-chromate reaction.

Because of the non-specificity of these tests, neither group should have made any claims as to the presence or absence of ethyl alcohol in tissues.

<sup>1</sup> (a) A. and J. Béchamp, *Compt. rend.*, **75**, 1830 (1872); **76**, 836 (1873); **89**, 573 (1879); (b) Rajewsky, *Arch. ges. Physiol.*, **2**, 122 (1875); (c) Vitali, *Ann. Chim. Farm.*, [4] **5**, 113 (1887); (d) Albertoni, *ibid.*, **6**, 250 (1887); (e) M. Nicloux, *Compt. rend. acad. sci.*, [10] **3**, 841 (1896); (f) Landsberg, *Z. physiol. Chem.*, **41**, 505 (1904); (g) Stocklasa, *Deut. med. Wochschr.*, **6**, 198 (1904).

<sup>2</sup> Arnheim and Rosenbaum, *Z. physiol. Chem.*, **40**, 220 (1904); Umber, *Z. klin. Med.*, **39**, 12 (1900).

Nevertheless, several of the investigators even went so far as to make quantitative determinations of the unknown volatile substances which are found in all tissue distillates. They determined these volatile substances: (a) as iodoform, (b) by titrating with standard chromic acid, (c) by oxidizing to acid and titrating with standard alkali.

Their results are reported as follows

Ford <sup>3</sup>	In animal blood	0.0057%
Nicloux <sup>4</sup>	In entire guinea pig	0.001%
Landsberg <sup>11</sup>	In rabbit muscle	0.028–0.038%
Maignon <sup>5</sup>	In dog blood	0.016–0.027%
Pringsheim <sup>6</sup>	In entire rat	0.044%
Pringsheim <sup>6</sup>	In rabbit blood	0.018%
Schweisheimer <sup>7</sup>	In human blood	0.0368%

The methods used by these experimenters are not specific for ethyl alcohol. It is common knowledge that the iodoform reaction is given by several volatile organic substances. The chromic acid titration method is based on color changes caused by reduction of the chromate; and ethyl alcohol is only one of many volatile organic substances that will reduce chromic acid. The method based on oxidation and subsequent titration of acidity is not specific for ethyl alcohol because all the various alcohols and aldehydes yield acids on oxidation.

Gettler and Tiber<sup>8</sup> have standardized this latter method, and by it have obtained an average yield of 0.00157% of ethyl alcohol from human brains. They state, however, that this value means simply that if alcohol is normally present in human brains, its average amount is 0.00157%.

Taylor reported finding traces of ethyl alcohol in dog muscle and identified the alcohol by making the ethyl *p*-nitrobenzoate derivative.<sup>9</sup>

Since there is no specific test for ethyl alcohol in the minute traces which we expected to find (*e. g.*, 0.015 g.—one-third of a drop—in an entire brain weighing 1500 g.), special micro-chemical methods had to be selected and devised. We planned to (a) isolate the ethyl alcohol in pure, anhydrous form; (b) determine the boiling point of the pure isolated product; (c) determine quantitatively its carbon content; (d) prepare some derivatives from it (*e. g.*, ethyl benzoate and ethyl iodide); and, finally, (e) determine the boiling points of these derivatives.

**The Tissue Distillation.**—The materials used in the experiments were human brains, livers and blood; dogs' brains, livers and blood; and pigs' brains (listed in Table

<sup>3</sup> Ford, *J. Physiol.*, **34**, 430 (1906).

<sup>4</sup> Nicloux, Thèse de Paris, 1900.

<sup>5</sup> Maignon, *Compt. rend. acad. sci.*, **140**, 1063 (1905).

<sup>6</sup> Pringsheim, *Biochem. Z.*, **12**, 143 (1908).

<sup>7</sup> Schweisheimer, *Deut. Arch. klin. Med.*, **109**, 271 (1912).

<sup>8</sup> Gettler and Tiber, *Arch. Path. Clin. Med.*, **3**, 75, 218 (1927).

<sup>9</sup> A. E. Taylor, *J. Biol. Chem.*, **15**, 217 (1913).

I). Of the human specimens, only those were selected that had been under observation in the hospital and in which we were positive that no alcohol had been administered, either internally as beverage or medicine, or externally by rubbing, for at least fifteen days before death. The blood was taken from laboratory workers who never drank alcoholic beverages.

The dogs had been kept in cages for two months and fed nothing but lean meat and water. The pigs' brains had been removed as soon as the animals were killed and sent directly from the slaughter house to the laboratory, where work was commenced immediately.

As soon as the tissues were removed from the body, they were sealed in clean glass containers and kept in the refrigerator until they were ice-cold. Then they were ground up and divided into 500-g. portions, each of which was placed in a one-liter flask with 300 cc. of water. This mixture was subjected to steam distillation, using a long, well cooled condenser with an adapter adjusted to dip into a little ice-cold water in a receiver that was packed in ice.

The distillation was continued on each 500-g. portion until 500 cc. of distillate had been collected; the three 500-cc. distillates from the same liver or brain were then combined for the isolation experiments. One composite sample was made of all the 500-cc. distillates from ten human livers; in the case of dogs' livers and brains, and human blood, where the original material weighed considerably less than 500 g., smaller apparatus was used and proportionately smaller distillates were collected.

The 1500 cc. of steam distillates was then subjected to fractional distillation. It must be pointed out that we were here working with very large volumes of extremely dilute solutions. If alcohol was present at all, these distillates contained only about

0.001% of ethyl alcohol. In our preliminary studies on such dilute alcohol solutions, it was found that the usual distilling flasks could not be used. We found that there is an appreciable loss of alcohol due to absorption by the rubber or cork stoppers and also by some of the alcohol being held back in the dead spaces above the exit tube of the flask and within the top of the condenser. We, therefore, devised entirely new distilling flasks as shown in Fig. 1. The condenser, flask and filling tube are in one piece, thus excluding all stoppers and dead spaces. Four sizes of these flasks, 1000, 500, 100 and 60 cc., were used in the fractional distillations.

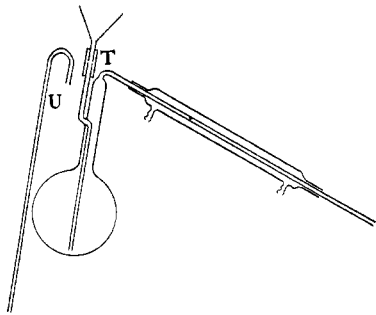

Fig. 1.—Distilling condensing apparatus (in one piece) (according to Gettler and Benedetti-Pichler): T, funnel for filling flask; U, siphon for emptying flask.

tions. From the work of E. Donitz, M. Nicloux and L. Bandner, M. J. Stritar, and our own experiments, we concluded that with very dilute (0.002%) alcohol solutions, if 40% by volume is distilled, all the alcohol is recovered in the distillate.<sup>10</sup>

In the first distillation the tissue steam distillates were acidified with sulfuric acid to keep back all volatile organic bases; 600 cc. was collected. For the second distillation it was made alkaline with sodium carbonate to keep back all volatile organic acids;

<sup>10</sup> E. Donitz, *Märker-Delbrück, Spiritus-Fabrikation*, p. 694 (1908); M. Nicloux and L. Bandner, *Z. anal. Chem.*, 38, 256 (1899); M. J. Stritar, *Z. physiol. Chem.*, 50, 24 (1906).

240 cc. was collected. The third distillation was carried out in neutral reaction; 100 cc. was collected. To these 100 cc. of distillate, freshly prepared silver oxide was added, corked, well shaken and allowed to stand for about one week. This treatment removed all aldehydes by converting them to acids, the latter being fixed as silver salts. Without filtering, this mixture was then distilled; 40 cc. was collected. Aliquot portions of the distillate were used for the quantitative determination of the alcohol, as later described. For the isolation of the alcohol, two further fractional distillations were performed, collecting 16 and 5 cc., respectively.

**Fractional Distillation with Special Rectification Flasks.**—Any further attempts fractionally to distil the 5-cc. distillates obtained above were hopeless, for, if 40% of the 5 cc. were distilled, only 2 cc. would be collected. The alcohol adhering to the large surface of the condenser would mean an appreciable loss of alcohol and it was obvious that rinsing the condenser would be out of the question when trying to concentrate alcohol.

Since we found that most of the alcohol comes over in the first ring of condensate and since we needed a distilling apparatus with condensing surface at a minimum, we devised what we have called the *Rectification Flask* (Fig. 2). With this apparatus we can obtain a very high concentration of alcohol with relatively little technique.

The 5 cc. of concentrated distillate obtained above was transferred to the rectification flask. A small amount of zinc dust was added, to prevent bumping and insure slow but regular boiling. To insure that the upper part of the flask would be absolutely dry inside, the section bd was carefully heated with a small Bunsen flame. When this part of the tube had again cooled to room temperature, a narrow strip of wet filter paper was wrapped around d, to help to keep this part cool.

The distillation was now started by heating the bulb of the flask with a small flame, the temperature being raised slowly and evenly. A ring of condensate rose slowly in the stem of the flask. The moment this passed the knee c, the flame was quickly removed. The ring of condensate collected at d. It was immediately sucked up into a capillary tube, sealed in at both ends and reserved for further work. The whole apparatus was allowed to cool at room temperature and the operation was repeated until several drop fractions had been collected in the same manner.

The boiling points<sup>11</sup> of the eight fractions of one set of experiments (all other sets gave similar values) were 74, 75, 75.6, 77, 79.8, 80.5, 82.4, 84.4°, respectively, indicating, first, that some liquid was present in the first three fractions, which had a much lower boiling point than ethyl alcohol; second, if ethyl alcohol were present in fractions 4, 5 and 6, it had been obtained in quite high concentration by a single rectification. The lower boiling liquid distilling in the first three fractions was found to be acetone. It was identified by (a) odor, (b) nitroprusside test, (c) conversion into crystals of *o*-nitrophenylhydrazone.

**The Micro Drying of the Rectified Liquids.**—The fractions boiling below 81° were

<sup>11</sup> All boiling point determinations in this work were done by F. Emich's micro method. Emich, *Monatsh.*, 38, 219 (1917).

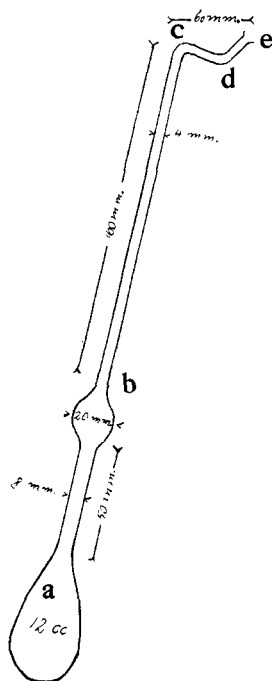

Fig. 2.—Micro-rectification flask (according to Gettler and Benedetti-Pichler).

combined and transferred to capillary tubes shown in Fig. 3. The bulbs of the tubes were previously filled with a relatively large amount of finely granulated calcium oxide or anhydrous copper sulfate. The capillary was centrifuged to force the liquid into the bulb. The open end was sealed and the tube placed in a boiling water-bath for five minutes. It was again centrifuged to bring the liquid into contact with the dehydrating agent, and then allowed to stand for three days at room temperature.

The bulb of the sealed capillary was then placed in the cavity of an aluminum heating block (Fig. 3, c); the latter was heated to 95° and kept constant for five minutes.

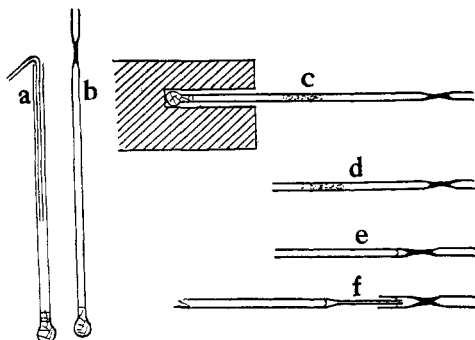

Fig. 3.—Drying tubes, drying block, and boiling point capillaries.

The alcohol distilled from the bulb and appeared as a condensate on the walls of the capillary outside of the heating block. The tube was removed from the block, cut in two at the middle, and the part holding the condensate was centrifuged to force the alcohol to the sealed end (Fig. 3, d, e). These dried droplets were fractionally distilled as follows.

**Fractionating with Emich's Micro Distilling Tube.**—The dry droplets of liquid obtained were transferred to an Emich micro distilling tube and fractionally distilled. Six to eight fractions were usually obtained and the

boiling point of each was determined. By this means the acetone was separated from the liquid boiling between 77 and 79°. <sup>12</sup>

The rise of the droplets in the capillary tubes during the micro boiling determinations on pure anhydrous ethyl alcohol behaved exactly as did the liquid (boiling between 77 and 79°) isolated from tissues, and both gave similar values, proving that the isolated liquid was ethyl alcohol.

**The Micro Determination of the Carbon Content of Isolated Ethyl Alcohol.**—For the determination of the carbon content of the ethyl alcohol isolated from tissues, we used the purified and perfectly dried fractions that boiled between 78 and 79°. The quantitative analysis by Pregl's micro method <sup>13</sup> showed that the droplets of liquid isolated from tissues which boil at 78 to 79° contain 51.8% carbon.

The theoretical carbon content of closely related substances is as follows

Methyl alcohol	37.5%	Propyl alcohol	60.0%
Ethyl alcohol	52.1%	Acetone	62.1%

Since the pure liquid that we isolated from tissues (b. p. 78 to 79°) had a carbon content of 51.8%, it served to prove that the isolated material was ethyl alcohol.

**Identification of Isolated Material as Ethyl Alcohol by Conversion to Ethyl Benzoate.**—To prepare the benzoate derivative, we used the fractions boiling between 77 and 80°. Ten to 20 mg. of the alcohol was placed in a glass tube measuring 10 cm. in length and 3 mm. in its inner diameter, and sealed at one end. An equal amount of benzoyl chloride was added, and the liquids were mixed by means of a bead on the end of a fine glass thread. The tube was then corked and allowed to stand overnight.

The next day enough sodium bicarbonate was added to neutralize all the benzoic

<sup>12</sup> Emich, "Lehrbuch Microchemie," 2d ed., Munich, 1926.

<sup>13</sup> Pregl, "Quantitative Organic Micro Analysis," 2d ed., P. Blakiston's Sons Co., Philadelphia, Pa., 1930.

acid and hydrochloric acid that had been formed, and a few drops of water were added. Most of the sodium salts remained undissolved. The contents were stirred occasionally with the glass bead until the odor of benzoyl chloride disappeared (usually three to six hours). Enough ether was then added to form a 3-cm. layer; the tube was corked and well shaken, and finally centrifuged. The supernatant ether layer was transferred to another tube of the same type by means of a capillary siphon, and enough freshly dehydrated potassium carbonate was added to form a layer 1 cm. deep. After these two substances were well mixed with the glass bead, the tube was corked and allowed to stand overnight.

An Emich micro fractionating tube, containing a small layer of asbestos, was freed from moisture by heating it in a small Bunsen flame. As soon as it was cold again, the ether layer described above was transferred to it in several separate portions by means of a capillary tube which placed the liquid right in the asbestos at the bottom. After the introduction of each portion, the ether was evaporated by resting the fractionating tube on a lighted electric bulb. The ester was thus collected quantitatively in the asbestos of the fractionating tube. The tube was finally heated gently above a micro burner, to remove the last traces of ether, but care was taken not to distil any of the ester.

The ether-free ester was fractionally distilled from the asbestos. The middle and end fractions were redistilled in the same manner, and the last three fractions were used

TABLE I  
TISSUES USED FOR THE ISOLATION AND IDENTIFICATION OF ETHYL ALCOHOL

No.	Tissue	Weight, g.	B. p. of the isolated EtOH, °C.	B. p. of the benzoate derivatives, °C.	B. p. of the iodide derivatives, °C.	Zeisel alkoxy reaction
1	1 Human brain	1800	79	182-204	71.5	Positive
2	4 Human brains	6300	77.9	190-208	71.0	Positive
3	1 Human brain	1265	78.1	185-205	68.0	Positive
4	1 Human brain	1225	77.8	180-205	69	Positive
5	1 Human brain	1500	78.2	188-207	71.7	Positive
6	10 Human livers	17000	78	190-206	..	Positive
7	1 Human liver	1225	78.2	180-204	72.5	Positive
8	1 Human liver	1000	78.1	186-205	71.9	Positive
9	1 Human liver	1180	77.8	190-205	70.2	Positive
10	1 Human liver	1290	78.2	189-207	70.8	Positive
11	1 Human liver	950	77	185-204	71.8	Positive
12	1 Human blood	25	77.8	182-201	..	Positive
13	3 Human blood	80	78.1	175-190	69.9	Positive
14	3 Human blood	90	77.6	185-204	71.8	Positive
15	1 Human blood	150	78.7	191-207	72.1	Positive
16	1 Human blood	45	77.9	188-206	71.9	Positive
17	2 Dog brains	125	77.1	.....	71.5	Positive
18	2 Dog brains	155	77.6	182-203	..	Positive
19	2 Dog brains	145	77.5	185-204	70.9	Positive
20	2 Dog livers	410	79.8	.....	..	Positive
21	2 Dog livers	520	77.6	183-203	..	Positive
22	2 Dog livers	440	78.9	.....	71.8	Positive
23	2 Dogs' blood	350	77	180-203	72.0	Positive
24	2 Dogs' blood	420	78	181-202	71.5	Positive
25	2 Dogs' blood	490	77.2	184-205	71.9	Positive
26	300 Pigs' brains	28000	..	.....	54	Positive
27	300 Pigs' brains	28200	78.2	189-206	72.0	Positive

for the micro boiling point determinations. The boiling points of the benzoate derivatives are given in Table I.

Although pure ethyl benzoate boils at  $212^{\circ}$ , it was found by the micro boiling point method that the values for the pure product actually range from  $205$  to  $213^{\circ}$ . Ethyl benzoate made from pure alcohol boiled at  $190$  to  $206^{\circ}$  and  $195$  to  $208^{\circ}$ . Since these figures compare so favorably with those of the benzoate made from tissue distillates, they prove that the derivative is ethyl benzoate. This ester was further identified by its odor and by its insolubility in water.

The production of ethyl benzoate corroborates that the liquid isolated from the tissues was ethyl alcohol.

**The Identification of Isolated Material as Ethyl Alcohol by Conversion to Ethyl Iodide.**—The preparation of the iodide derivative is based on the interaction of ethyl alcohol and hydriodic acid. The apparatus and method used was exactly the same as shown in Fig. 4 and described under the quantitative determination (to follow), except that the receiver was empty and was packed in a mixture of acetone and solid carbon dioxide in a Dewar flask.

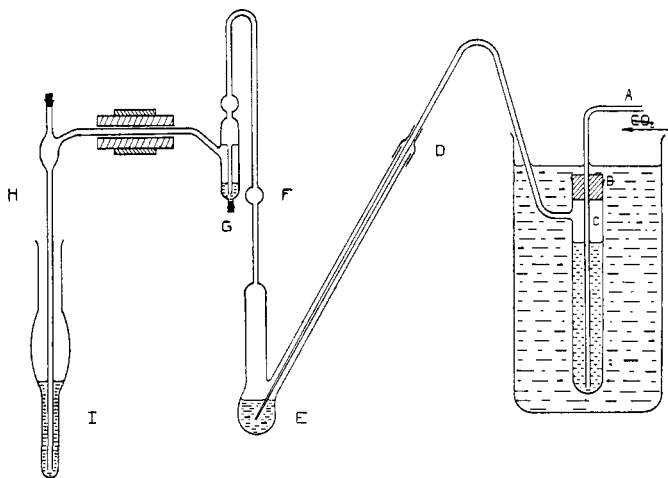

Fig. 4.—Pregl's ethoxy apparatus (as modified by Gettler and Niederl): A, carbon dioxide inlet tube; B, stopper; C, side-arm test-tube; D, inlet tube; E, hydriodic acid bulb; F, condenser; G, washer; H, capillary outlet; I, receiver.

Five cc. of concentrated aqueous distillate from tissues was placed in the side-arm test-tube. Soon after starting the experiment, ice was noticed in the receiver (kept at  $-80^{\circ}$  by the carbon dioxide-acetone mixture), but the operation was continued for thirty to fifty minutes, until a heavy liquid and a yellowish-white solid had formed. The receiver was then removed from the apparatus and allowed to attain room temperature, the solid melted and settled on top of a few drops of a heavy oil; the two liquids were not miscible.

The top layer, which was found to be water, was drawn off by means of a capillary siphon and the heavy oil was transferred by another capillary siphon to a micro centrifuge tube. A drop of distilled water was added and the mixture was stirred by a glass bead on a fine glass thread. By centrifuging the mixture a clear separation was effected and the water layer on top was then drawn off. This washing procedure was repeated several times.

For the identification of the ethyl iodide, the boiling point was determined. The results are listed in Table I.

The boiling point of absolutely pure ethyl iodide is  $72.3^{\circ}$ . The figures obtained with our product are close enough to this to indicate that the isolated compound is ethyl iodide. The uniformly lower boiling points may be due to the persistent presence of some slight impurities.

**Quantitative Determination of the Alcohol in Tissues.**—For our quantitative micro method we essentially followed Pregl's adaptation of Zeisel's reaction for alkoxy groups. This is based on the formation of ethyl iodide by the direct interaction of ethyl alcohol and hydriodic acid and the subsequent quantitative determination of the silver iodide precipitated when the ethyl iodide is absorbed in an alcoholic silver nitrate solution. We have, however, made some constructive changes in both the apparatus and the method so that they are now applicable to extremely dilute ethyl alcohol solutions (0.02% and less), and have standardized the method for a total alcohol content of 0.1 mg. to 1 mg.<sup>13,14</sup>

The apparatus consists of a Kipp generator for the production of carbon dioxide, an especially constructed side-arm test-tube for the solution to be tested, Pregl's micro ethoxy apparatus, and a receiver containing an alcoholic silver nitrate solution,<sup>15</sup> arranged as shown in Fig. 4.

Holding the micro ethoxy apparatus in a horizontal position, about 1 cc. each of 5% solutions of sodium thiosulfate and cadmium sulfate were introduced into the washer g by a capillary pipet. The purpose of the sodium thiosulfate is to absorb any free iodine that might be liberated during the course of the experiment; the cadmium sulfate, to remove hydrogen sulfide or any other volatile sulfides. The opening of g was then tightly closed with a tiny cork, it was inverted to its proper position, and 1.5 cc. of hydriodic acid, sp. gr. 1.70 (Merck's special), was placed in the bulb e. Five grams of anhydrous potassium carbonate was placed in the side-arm test-tube, to lower the vapor pressure of the water and to facilitate the separation of the alcohol in the liquid to be tested.

Five cc. of concentrated tissue distillate was placed in the side-arm test-tube. When all connections of apparatus were made, the latter was heated in a water-bath to facilitate the volatilization of the alcohol present. The outlet from the Kipp generator was opened just far enough to allow carbon dioxide to pass in at the rate of two or three bubbles a second; then the hydriodic acid in e was heated to slow boiling. The process was stopped when no more precipitation occurred in the receiver containing the alcoholic silver nitrate.

One cc. of water and five drops of nitric acid were added to the precipitated addition compound ( $\text{AgI} \cdot 2\text{AgNO}_3$ ) in the receiver, and the whole was heated in a boiling water-bath. This hydrolyzed the addition compound, leaving the silver iodide in a nicely precipitated, filterable form. This precipitate was quantitatively transferred to a micro halogen filter tube (prepared and filled according to Pregl's method), and washed with alcohol. The tube was then placed in a micro heating block and dried at  $120^{\circ}$  in vacuum, using a suitable air filter. When completely dry (about ten minutes) and at constant weight the tube was weighed on a micro chemical balance to within 0.001 mg.<sup>13</sup>

Each milligram of silver iodide produced by this reaction represents 0.196 mg. of

<sup>14</sup> S. Zeisel, *Monatsh.*, **6**, 989 (1885); S. Zeisel and R. Fanto, *Z. landw. Versuchsw.*, **5**, 729 (1902); *Z. anal. Chem.*, **72**, 549 (1903).

<sup>15</sup> Twenty grams of silver nitrate dissolved in 500 g. of 95% alcohol; solution boiled three to four hours under reflux on water-bath. Reduced silver separates in finely divided form; after standing for two days, supernatant liquid decanted into dark stock bottle.



ethyl alcohol. Under the experimental conditions of this reaction, recovery is not complete and a correction value must be figured in the calculations. Our control experiments indicated a correction of 0.273; therefore (mg. of AgI + 0.273)  $\times$  0.196 = mg. of ethyl alcohol in 5 cc. of distillate analyzed.

The tissues that were used in these determinations and the results obtained are listed in Table II. The average content of ethyl alcohol in these tissues that were known to be non-alcoholic is as follows: human brain, 0.0004%; human liver, 0.00256%; human blood, 0.004%; dog brain, 0.0003%; dog liver, 0.0007%; dog blood, 0.0013%; pigs' brains, 0.00007%.

TABLE II  
AMOUNT OF ETHYL ALCOHOL PRESENT IN NORMAL TISSUES

No.	Specimens	Tissues used, g.	Ethyl alcohol present in mg. per 100 g.	Per cent.
1	1 Human brain	1800	2.72	0.00027
2	4 Human brains <sup>a</sup>	6300	3.27	.00033
3	1 Human brain	1265	5.45	.00055
4	1 Human brain	1225	4.35	.00044
5	10 Human livers <sup>a</sup>	17000	7.56	.00076
6	1 Human liver	1225	25.05	.00250
7	1 Human liver	1000	39.90	.00400
8	1 Human liver	1180	22.06	.00220
9	1 Human liver	1290	55.35	.00550
10	1 Human liver	950	4.84	.00040
11	1 Human blood	25	45.31	.0045
12	2 Human blood <sup>a</sup>	55	47.1	.0047
13	1 Human blood	30	38.2	.0038
14	1 Human blood	25	32.4	.0032
15	300 Pigs' brains <sup>a</sup>	28000	0.68	.00007
16	2 Dogs' brains <sup>a</sup>	125	3.30	.0003
17	2 Dogs' livers <sup>a</sup>	410	6.90	.0007
18	2 Dogs' blood <sup>a</sup>	350	13.70	.0013

<sup>a</sup> Composite samples.

Special experiments were made to determine whether there might be any change in the alcohol content of tissues after removal from the body. In one of these approximately equal amounts of blood from three non-drinking persons were combined into one 110-cc. sample. One half of this sample was analyzed at once for alcohol content; the other half was kept in the refrigerator overnight and then analyzed. The results were 0.0050% and 0.0044%, respectively, indicating that the alcohol must have been present when the blood was taken from the body, not formed after removal.

**Acknowledgment.**—We wish to thank Mr. Pierre du Pont and Doctor Samuel Lambert for the interest they have taken in this work.

### Summary

Apparatus has been devised for the isolation of pure, anhydrous ethyl alcohol from extremely dilute solutions (0.0025% or less) as found in tissues: (a) distillation flask with condenser and filling tube, all in one piece, no corks needed, thus obviating the loss of volatile matter in stoppers and dead spaces; (b) a rectification flask in which the condensing surfaces are

kept at a minimum. A single distillation yields a few drops of very high proof alcohol, b. p. 78 to 79°.

The isolated alcohol was dried by calcium oxide or anhydrous copper sulfate in one end of a sealed capillary; it was then distilled into the other end of the same sealed tube by means of a heated aluminum block.

The perfectly dry material was transferred from the capillary to an Emich micro distilling tube and fractionally distilled. With this tube even fractions of a drop can be distilled, and by this means the acetone which is always present in tissues was separated from the ethyl alcohol. (Other volatile substances, such as aldehydes, ketones, organic acids and bases, were removed at various other steps during the procedure.)

Micro boiling point determinations were made on the pure isolated ethyl alcohol for purposes of identification.

The ethyl alcohol was further identified by its solubility and by the quantitative determination of its carbon content.

From the ethyl alcohol isolated from tissues, using a micro technique, the ethyl benzoate derivative was prepared; it was identified by its boiling point, solubility and odor.

From the ethyl alcohol isolated from tissues, using a micro technique based on Pregl's alkoxy apparatus, the ethyl iodide derivative was prepared; it was identified by its boiling point and solubility.

The amounts of alcohol normally present in tissues were determined by a modification of Pregl's micro method, using the Zeisel reaction.

The average amount of ethyl alcohol present normally in body tissues was found as follows: human brain, 0.0004%; human liver, 0.00256%; human blood, 0.004%; dog brain, 0.003%; dog liver, 0.0007%; dog blood, 0.0013%; pig brain, 0.00007%.

**Conclusion.**—Pure anhydrous ethyl alcohol was isolated and identified from the brain, blood and liver of non-alcoholic humans, dogs and pigs.

NEW YORK CITY, N. Y.